

DOPPLER-FREE TWO-PHOTON OPTOGALVANIC SPECTROSCOPY IN HELIUM [☆]J.E.M. GOLDSMITH ^{*} and A.V. SMITH*Joint Institute for Laboratory Astrophysics, University of Colorado, and National Bureau of Standards, Boulder, Colorado 90309, USA*

Received 15 January 1980

Optogalvanic detection is used in the Doppler-free observation of the $^4\text{He } 2^3\text{S}-5^3\text{S}$ and $2^3\text{S}-5^3\text{D}$ two-photon transitions.

We report the use of Doppler-free two-photon optogalvanic spectroscopy (TOGS) [1] in the observation of two-photon transitions in helium. Optogalvanic detection [2] provides a simple and powerful alternative to fluorescence detection of two-photon transitions. Practical application of TOGS has been demonstrated previously in a study of transitions from both metastable and non-metastable levels in the 3s configuration of neon using a cw dye laser system [1]. Using a unique high-power narrow-band pulsed dye laser system [3], we have extended the application of TOGS to the much more demanding task of observing Doppler-free two-photon transitions in helium.

Optogalvanic detection is a sensitive technique for monitoring optical absorption in a discharge medium by observing changes in the discharge impedance produced by the population redistribution. It has several features of importance for spectroscopic applications. It does not require an optical detector to monitor the transition (which may be of special importance in the infrared and far ultraviolet), the discharge can efficiently populate high-lying metastable and non-metastable levels, and dynamic processes occurring within the discharge can be studied directly [4].

TOGS has several advantages over fluorescence detection in observing two-photon transitions from levels populated in a discharge. With fluorescence de-

tection, it is generally only practical to monitor one particular decay channel of the possibly many channels from the excited state. Moreover, the dominant decay channel may be at an inconvenient wavelength for efficient fluorescence detection, or nonradiative decay from the excited state may decrease the probability of decay by fluorescence. In addition, the optical throughput and solid angle covered by fluorescence detection schemes are often limited. TOGS does not suffer from any of these limitations.

It is also possible to study two-photon excitation in the afterglow of a pulsed discharge [5,6]. This eliminates the fluorescence background produced by the discharge, and decreases energy level shifts caused by electrical fields in the discharge to the extent that the fields decay more rapidly than the excited state population. Afterglow techniques are limited to studies of transitions from metastable levels, however. Since energy level shifts caused by the discharge can be studied systematically by varying the discharge parameters, and thus corrected for, level shifts are not a severe limitation of TOGS.

We use a high-power pulsed laser system to observe transitions from the $^4\text{He } 2^3\text{S}$ state. The high-power system is used because the energy interval between real and virtual intermediate states is about a factor of 100 greater in helium than in neon, decreasing the two-photon absorption transition rate by roughly a factor of 10^4 . The experimental apparatus used in the helium studies is diagrammed in fig. 1. The laser system, described in detail elsewhere [3], employs a chain

^{*} This work was supported by the National Science Foundation through grant PHY76-04761 to the University of Colorado.

^{*} NRC-NBS Postdoctoral Fellow, 1979-80.

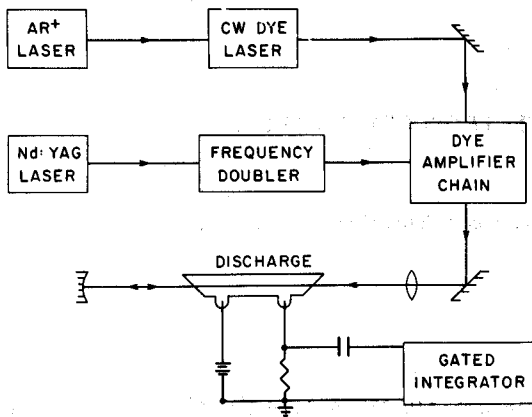

Fig. 1. Experimental apparatus for Doppler-free two-photon optogalvanic spectroscopy of helium.

of three dye amplifiers pumped by a frequency-doubled long-pulse Nd:YAG laser to amplify the output of a single-mode cw dye laser, producing pulses of 60 ns duration, 20 kW peak power, and 20 MHz bandwidth at a repetition rate of 10 Hz. The amplified beam is focused into the positive column of the helium discharge tube by a 1 m focal length lens and retroreflected by a 1 m radius of curvature mirror to provide the counter-propagating waves for Doppler-free two-photon excitation.

The home-made coaxial dc discharge tube, originally used to provide the gain medium in a helium-neon laser, has an 18 cm long, 3 mm diameter bore with identical 5 cm long, 2 cm diameter hollow aluminum anode and cathode. The tube is filled with 1 Torr of pure ^4He and operated with a typical dc current of 5 mA. The optogalvanic signal which appears across the 100 k Ω ballast resistor is monitored by a gated integrator through a coupling capacitor. A minicomputer scans the dye laser wavelength, monitors the laser power, and plots the two-photon signal.

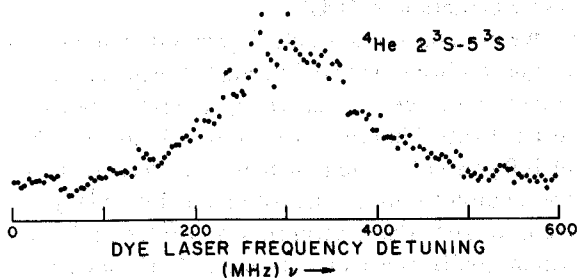

Fig. 2. $^4\text{He } 2^3\text{S}-5^3\text{S}$ TOGS signal.

Fig. 2 shows a scan of the $^4\text{He } 2^3\text{S}-5^3\text{S}$ two-photon resonance at 597 nm. Each point is the average of 20 laser pulses, with the computer programmed to accept only pulses with energies within a 10 percent window of a preset pulse energy. The discharge tube is optically isolated by a 50 ns optical delay line to eliminate feedback into the laser from the retroreflected beam.

Fig. 3 shows a scan of the $^4\text{He } 2^3\text{S}-5^3\text{D}$ two-photon resonance at 587 nm. Each point is from a single laser pulse, with the computer again programmed to accept only pulses within a 10 percent energy window. Optical isolation is provided by a linear polarizer-quarter wave plate combination, rather than an optical delay time. The 284 MHz $J=2-J=1$ fine-structure splitting of the 5^3D state [7] shows up clearly (as a 142 MHz splitting measured in the detuning of the dye laser). The 20 MHz $J=3-J=2$ splitting [8] is not resolved.

Both the $2^3\text{S}-5^3\text{S}$ and the $2^3\text{S}-5^3\text{D}$ transitions produce positive voltage pulses, with risetimes on the order of 1 μs followed by a slower decay (5-10 μs). The positive voltage pulses indicate an increase in discharge current, implying an enhancement of ionization caused by the optical excitation. This indicates that enhanced ionization from the 5^3S and 5^3D states is more significant than any decrease in ionization caused by a decrease in the population of the metastable 2^3S state. The enhancement is partly due to associative ionization ($\text{He}^* + \text{He} \rightarrow \text{He}_2^+ + \text{e}$) of the 5^3S and 5^3D states (the 2^3S state is well below threshold for associative ionization), but a quantitative description would require taking into account many de-

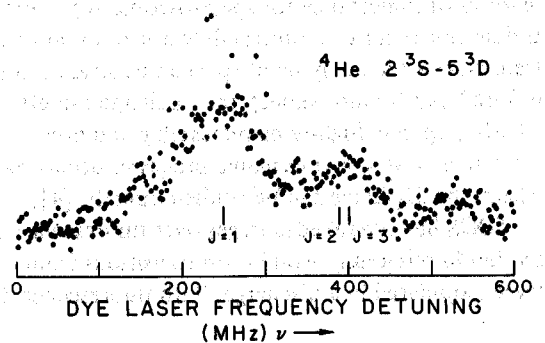

Fig. 3. $^4\text{He } 2^3\text{S}-5^3\text{D}$ TOGS signal. The vertical lines above the frequency axis indicate the fine-structure splitting of the 5^3D state.

tails of the discharge dynamics. The relationship of discharge dynamics to one-photon optogalvanic signals is discussed for the helium 2^3P-3^3D transition in ref. [4], and for a large number of neon transitions in ref. [9].

Much of the noise in the spectra in figs. 2 and 3 is due to wavelength independent positive-polarity background pulses produced by the laser. The time scale of the background pulses is similar to the two-photon signals, so they cannot be discriminated against with the gated integrator. The background is most likely due either to photoionization from high-lying levels populated by the discharge, or to absorption of the intense laser pulse in the far wings of a dipole-allowed transition. (In particular, the 587 nm wavelength required for the 2^3S-5^3D transition is only 0.5 nm from the wavelength of the 2^3P-3^3D transition.)

It should be possible to make considerable improvement in our signal-to-noise ratio. We did not investigate the effect of varying the helium pressure in the sealed discharge tube. Since it seems very likely that most of the observed linewidth is due to pressure broadening, operation of the discharge at lower pressures should lead to narrower lines and an improved signal-to-noise ratio, both because the area under the resonance curve should remain the same, and because the amplitude of the non-resonant background signal discussed in the preceding paragraph would most likely be reduced. Optimization of the discharge tube design and excitation circuit for use with optogalvanic spectroscopy could also lead to significant improvements in the signal-to-noise ratio.

TOGS may provide a practical means of observing Doppler-free two-photon transitions from the non-metastable helium 2^3P state, in addition to transi-

tions from the metastable 2^3S and 2^1S states. A high-power laser source operating near 690 nm could provide direct optical access to high-lying P and F states from the 2^3P state. The combination of TOGS with the Doppler-free technique of intermodulated optogalvanic spectroscopy [10] may make practical an even wider range of Doppler-free studies of optical transitions in discharges, both for spectroscopic purposes and for investigations of discharge processes.

We would like to thank Dr. John L. Hall for providing the discharge tube used in this experiment.

References

- [1] J.E.M. Goldsmith, A.I. Ferguson, J.E. Lawler and A.L. Schawlow, *Optics Lett.* 4 (1979) 230.
- [2] R.B. Green, R.A. Keller, G.G. Luther, P.K. Schenck and J.C. Travis, *Appl. Phys. Lett.* 29 (1976) 727.
- [3] G.L. Eesley, M.D. Levenson, D.E. Nitz and A.V. Smith, *IEEE J. Quantum Electron.*, in press.
- [4] J.W. Lawler, *Phys. Rev. A*, submitted for publication.
- [5] E. Giacobino, F. Biraben, G. Grynberg and B. Cagnac, *J. Phys.* 38 (1977) 623.
- [6] E. Giacobino, E. DeClercq, F. Biraben, G. Grynberg and B. Cagnac, in: *Laser spectroscopy IV*, eds. H. Walther and K.W. Rothe (Springer-Verlag, Berlin, 1979) pp. 626-627.
- [7] G. Astner, L.J. Curtis, L. Liljeby, S. Mannervik and I. Martinson, *J. Phys.* B9 (1976) 1345.
- [8] J.P. Descoubes, in: *Physics of one- and two-electron atoms*, eds. F. Bopp and H. Kleinpoppen (North-Holland, Amsterdam, 1969) pp. 341-347.
- [9] K.C. Smyth and P.K. Schenck, *Chem. Phys. Lett.* 55 (1978) 466.
- [10] J.E. Lawler, A.I. Ferguson, J.E.M. Goldsmith, D.J. Jackson and A.L. Schawlow, *Phys. Rev. Lett.* 42 (1979) 1046.