

Deterministic Nanosecond Laser-Induced Breakdown Thresholds In Pure and Yb³⁺ Doped Fused Silica

Arlee Smith, Binh Do

Laser, Remote Sensing, Plasma and Complex System Science Department
Sandia National Laboratories, Albuquerque, New Mexico

Mikko Soderlund

Liekki Corporation,
Lohja, Finland

Abstract:

The objective of this work is to understand catastrophic optical damage in nanosecond pulsed fiber amplifiers. We used a pulsed, single longitudinal mode, TEM₀₀ laser at 1.064 μm , with 7.5-nsec pulse duration, focused to a 7.45- μm -radius spot in bulk fused silica. Our bulk damage threshold irradiance is corrected to account for self focusing. The pulse to pulse variation in the damage irradiance in pure silica is less than 1%. Damage is nearly instantaneous, with an induction time much less than 1 ns. These observations are consistent with an electron avalanche rate equation model, using reasonable rate coefficients. The bulk optical breakdown threshold irradiance of pure fused silica is $5.0 \times 10^{11} \pm 7\%$ Watts/cm². We also measured the surface damage threshold irradiance of 1% Yb³⁺ doped fused silica preform of Liekki Yb1200 fiber, and found it is equal to that of pure silica within 2%.

The optical damage morphology is reproducible from pulse to pulse. To facilitate the morphology study we developed a technique for locating the laser focus based on the third harmonic signal generated at the air-fused silica interface. This gives a very small uncertainty in focal position ($\sim 10 \mu\text{m}$) which is important in interpreting the damage structure. The surface third harmonic method was also used to determine the laser focus spot size and verify beam quality.

Earlier reports have claimed that the damage irradiance depends strongly on the size of the focal spot. We varied the focal volume to look for evidence of this effect, but found none.

I. Introduction:

Laser induced breakdown leading to optical damage in optically transparent material such as fused silica has been studied by many researchers since the invention of laser more than four decades ago. It is important in the development and application of high power lasers because laser induced damage is an ultimate limit to system performance. However, the literature on nanosecond damage of fused silica is too confusing to use as basis for fiber amplifier design; the reported values of damage threshold irradiance/fluence vary over orders of magnitude. For example, in 1980, M. Soileau and M. Bass reported a damage threshold irradiance of fused silica of 605 GW/cm² for a pulse duration of 31 ns, and a beam radius of 6.15 μm [1]. More recently L. Gallais *et. al.* reported a damage threshold irradiance of fused silica of 22 ± 5 GW/cm² for a pulse duration of 7 ns, and a beam radius of 6 μm [2]. We need better measurements of the

optical breakdown threshold, and a better understanding of the optical breakdown process. We also need to measure the damage threshold of Yb³⁺-doped fused silica. In addition, we wish to determine out whether the optical breakdown threshold is set by irradiance or fluence.

In our studies of optical breakdown we address a number of issues:

1. Detection of optical breakdown.
2. Time and spatial profiles of laser pulses.
3. Location and the size of the laser focus.
4. Role of self focusing.
5. Stimulated Brillouin Scattering (SBS).

With these accounted for we can determine the bulk optical breakdown damage threshold, and also study the damage mechanism and morphology, the possible effects of focal size, and the influence of Yb³⁺ doping in fused silica.

II. Experimental set-up and technique.

1. Detection of optical breakdown.

Intense laser light excites electrons into the conduction band by three processes: Tunneling ionization, multiphoton ionization, impact ionization. The critical electron density gives a plasma frequency equal to the optical frequency, ω

$$(e^2 n_{\text{crit}}) / (m \epsilon \epsilon_0) = \omega^2, \quad (1)$$

where e is the electron charge, n is the free electron density, m is the electron mass, ϵ is the relative permittivity of the medium, and ϵ_0 is the vacuum permittivity. For 1064 nm light, the critical density of fused silica is $2.08 \times 10^{21}/\text{cm}^3$. If the free electron density reaches this level, incoming laser light is strongly reflected. However, the energy deposited in the silica by free electrons at this density is sufficient to cause permanent damage through melting and fracturing. At the onset of optical breakdown the following processes occur [3]:

- a. Generation of a high-density plasma at the focus that appears as a bright white spot due to emission of broadband light. We detect the white light as the primary indicator of optical breakdown.
- b. A drastic decrease in the transmitted laser power as the incident laser pulse is absorbed, reflected and scattered by the dense plasma in the focal region.
- c. A decrease in the power of the transmitted HeNe probe beam due to absorption and scatter by the plasma.

In our measurements we recorded the incident pump beam, the transmitted pump beam, the broadband light emitted by the plasma, and the transmitted probe beam.

2. Experimental set-up.

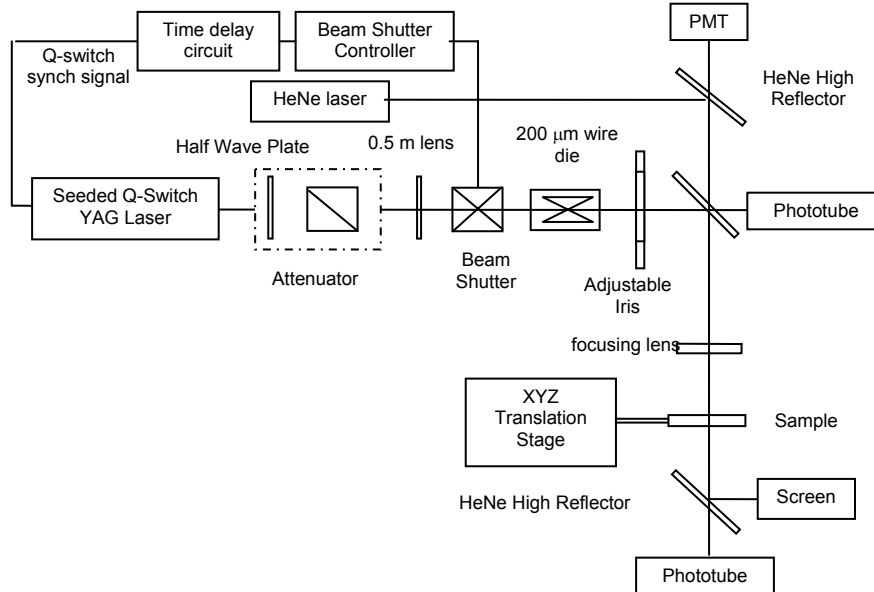

Figure 1: Experimental set-up.

Figure 1 shows our measurement apparatus. Damage is created by light from a single longitudinal mode, injection seeded, Q-switched YAG laser. It is important to use a single longitudinal mode laser because its pulses have a well defined temporal shape free of mode beating. A multi longitudinal mode laser pulse consists of numerous temporal spikes, making a measurement of the power at the instant of breakdown nearly impossible. For most of our measurements we used a single laser pulse to damage the sample. To extract a single pulse or a limited number of pulses and still keep the Q-switched oscillator locked to the seed laser we used an external shutter synchronized to the Q-switch. We varied the pulse energy using a half wave plate and a high energy cube polarizer. The spatial filter consists of a 200 μm diameter wire die followed by a variable iris, adjusted to clip the beam at the first Airy null, filtered the spatial mode, making it nearly TEM_{00} . We used fast phototubes (Hamamatsu, R1193U-51) to record the incident and the transmitted pump beams, and a photomultiplier (Hamamatsu, R406) to record the broadband breakdown light emitted from the focus. A HeNe probe beam was aligned coaxially with the pump and displayed on a screen after passing through the sample. The sample was mounted on a motorized 3-axis translation stage, and we focused the pump beam into the sample using 1", 1.5", and 2" focal length, best form lenses manufactured by CVI.

3. Time and spatial profiles of laser pulses.

The temporal profile of the laser pulse is free of mode beating as may be seen by the profile displayed in figure 2. Pulses were highly reproducible, with shot to shot energy variations of approximately 1%.

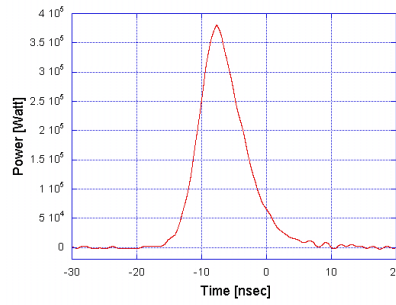

Figure 2: The temporal profile of the Q-switched laser pulse. The FWHM is 7.5 ns.

The spatial profile of the beam before reaching the sample is shown in figure 3. The profile is nearly Gaussian.

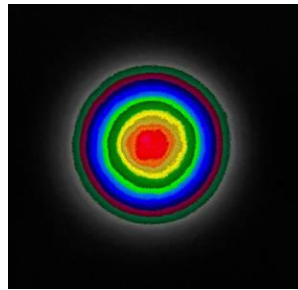

Figure 3: Spatial profile of the Q-switched laser beam before entering the sample.

4. Location and the size of the laser focus.

For both the self focusing correction and for damage morphology studies it is important to precisely measure the size and location of the focus. We measure both using the surface third harmonic signal generated by air-sample interface. Third harmonic light is radiated due to the broken symmetry at the air-solid interface [4]. This method is non-destructive and gives a focal position uncertainty less than 10 μm (for 1" focal length lens). The third harmonic pulse energy for a focused lowest order Gaussian beam with focal waist w_0 is proportional to

$$U_{3\omega} = C / w^4 = C / (z_R^2 + [z - z_0]^2)^2. \quad (2)$$

Figure 4 shows the measured third harmonic energy versus the z position of the sample, fitted to a line with the form of Eq. (2).

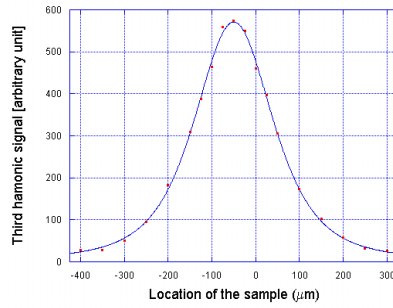

Figure 4: Surface third harmonic signal as a function the z position of the sample.

The signal is maximum when the beam waist is lies at the sample surface, so the surface is located to within $10 \mu\text{m}$. The excellent agreement between the measured values and the functional form is a strong indicator of excellent beam quality ($M^2=1.0$). The Rayleigh range, z_R , derived from the fit to the measured signal gives a beam waist of $7.45 \mu\text{m}$ for the $1''$ focal length lens. This agrees well with much more difficult and time consuming knife edge measurements of the waist size.

5. Self focusing.

Any bulk damage measurement must take account of self focusing. The refractive index of fused silica may be approximated by

$$n = n_0 + n_2 I, \quad (3)$$

where n_0 is the normal refractive index of silica and n_2 is the nonlinear index. The influence of self focusing on a Gaussian beam when the power is below the self focusing power is to move the focus down stream and decrease its focal waist. The correction factor for the maximum irradiance in the presence of self focusing depends on the instantaneous power and on the depth of focus inside the sample. The correction factor is plotted in Figure 5 for different focal depths, measured in Rayleigh ranges, and for different powers measured in units of the self focusing power.

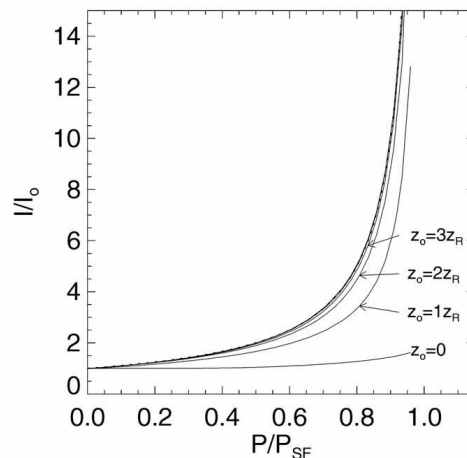

Figure 5: Irradiance enhancement for different depths of focus.

The self focusing power is given by

$$P_{sf} = (0.15 \lambda^2) / (n n_2) . \quad (4)$$

For focal depths of four or more Rayleigh ranges the irradiance correction is

$$I_{corrected} / I = 1 / (1 - P/P_{sf}) . \quad (5)$$

The nonlinear refractive index n_2 is different for linearly and circularly polarized light, so for silica at 1064 nm, $P_{sf}(\text{lin}) = 4.3$ MW, and $P_{sf}(\text{cir}) = 5.9$ MW.

6. Stimulated Brillouin Scattering (SBS).

SBS is another effect that can influence damage measurements. It can reflect a phase conjugated beam which can interfere with the incoming beam to create antinodes of high irradiance, thus lowering the apparent damage threshold. Alternatively, it can reflect the incoming beam before it reaches the focus, thus raising the apparent threshold. Either way, it should be avoided if possible. We estimate the SBS threshold for a focused Gaussian beam by setting the product of the Brillouin gain and the Rayleigh range to 30,

$$G_o I_o z_R = 30. \quad (6)$$

Using expressions relating the Rayleigh range and the irradiance to the power and the focal waist gives

$$P_{th} = (30 \lambda) / (2 g_o). \quad (7)$$

The threshold power is independent of the strength of focus, and for silica this equation gives $P_{th} = 0.3$ MW for cw light. The SBS build up time is approximately 30 ns, so the SBS threshold for a 10 ns pulse is estimated to be 0.9 MW. Experimentally, we found the SBS threshold in D1 fused silica for linearly and circularly polarized light to be 0.85 MW. Figure 6 shows incident, transmitted, and amplified SBS beams. The pulse reflected by SBS propagated back into the laser and was amplified before returning to the sample so it reappeared about 50 ns after the main pulse and appears as the delayed weak pulse in the oscilloscope trace.

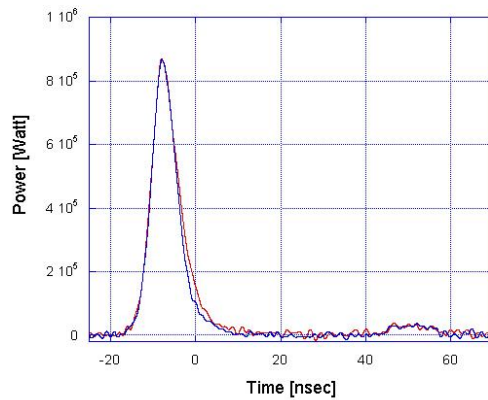

Figure 6: Incident (red) and transmitted (blue) waveforms of a pulse slightly above the SBS threshold. $w_0 = 17\mu\text{m}$, $t_0(\text{FWHM}) = 7.5\text{ns}$.

The SBS threshold power was nearly constant, independent of focal waist size, so we can plot the threshold peak irradiance as a function of waist size as shown in Figure 7. For reliable damage measurements we must use conditions that avoid the shaded SBS zone.

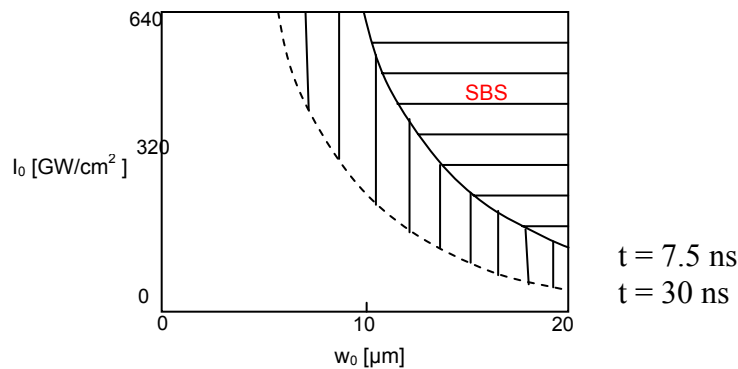

Figure 7: Diagram of SBS threshold for pulse durations of 7.5 ns and 30 ns.

III. Experimental results and discussion.

1. Laser induced damage thresholds in fused silica for seeded and unseeded lasers.

To avoid possible surface damage we focused 9.57 mm into sample, when using the 1" focal length lens. This is many times the Rayleigh range of $238\mu\text{m}$. We used a single laser pulse at different locations in the sample, gradually increasing the pulse energy until optical breakdown occurred. The pulse energy difference between 100% and 0% damage probability was less than 2.0%. This sharp damage threshold was independent of spot location across the samples, and different fused silica types (Corning A0, B0, B1, D0, D1, D3, D5) gave identical results.

Figure 8 shows the transmitted pulse profiles as the pulse energy is varied in the vicinity of the damage threshold. They show that the induction time is much shorter than the pulse duration and that breakdown occurs at a fixed irradiance rather than a fixed

fluence. The threshold power is 374 kW for linearly polarized light and 387 kW for circularly polarized light, corresponding to irradiances of $5.0 \pm 7\%$ GW/cm² for both polarizations after correcting by approximately 16% for the effect of self focusing.

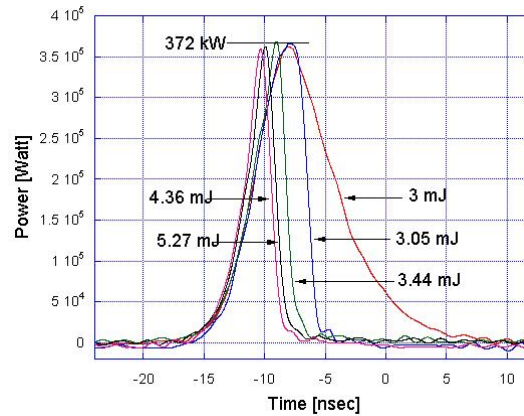

Figure 8: Transmitted waveforms for pulse energies near the optical breakdown threshold, $w_0 = 7.45$ mm, t_0 (FWHM) = 7.5 ns.

We also measured the damage threshold using unseeded laser pulses. Because every unseeded pulse is different, we used 3000 pulses of fixed energy at each sample location. If damage occurred in those 3000 shots, we counted it as a go, otherwise it was a nogo, and this process repeated ten times at different locations to give the damage probability versus pulse energy. The damage thresholds of fused silica for seeded and unseeded pulses are shown in Fig. 9. The energy gap between 100% and 0% probability using unseeded pulses was about 15%, and the pulse energy was 4 times lower than for seeded pulses.

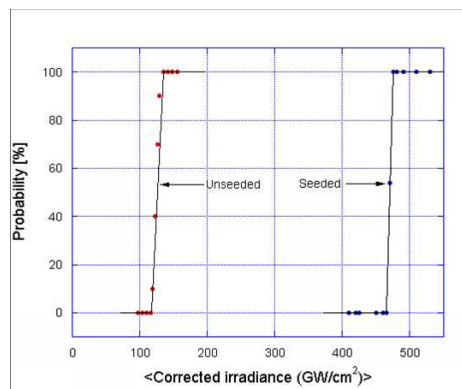

Figure 9: Statistical and deterministic behaviors of optical breakdown induced by unseeded and seeded pulses.

The reduced threshold can be explained in terms of the temporal structure of the unseeded pulses and the fast onset of damage. The linewidth of the unseeded pulses is approximately 30 GHz and the longitudinal mode spacing is 250 MHz. If we assume there are 8 randomly phased modes with a Gaussian amplitude distribution, reflecting the

nature of the starting quantum noise, the output pulse consists a series of spikes similar to the simulated pulse shown in Fig. 10. The width of the spikes is approximately 10 ps, and the peak power for the highest spike is approximately 4 times the maximum power of a seeded pulse of the same energy.

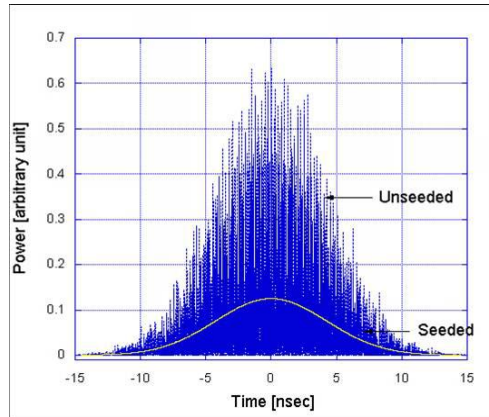

Figure 10: The simulated temporal profile of unseeded and seeded laser pulses of the same energy.

This description of the unseeded pulses, combined with the data of Fig. 9 reinforces the notion that irradiance is the deciding factor for optical breakdown and that the damage induction time is 30 ps or less.

2. Damage morphology.

The bulk damage morphology in silica is quite reproducible from pulse to pulse. Figure 11 shows a side view of several damage spots created by single longitudinal mode pulses of energy just slightly above the damage threshold.

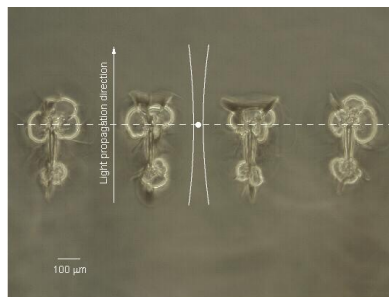

Figure 11: Side view of optical damage spots in fused silica. The pulse energy was slightly above the damage threshold.

The dashed line shows the location of the focal waist, and the size of the dot indicates the uncertainty ($\pm 10 \mu\text{m}$) in waist depth. The two curved lines indicate the beam size one Rayleigh range either side of the focus. Our interpretation of the damage is that optical breakdown starts at the exact waist where the laser intensity is highest (the self focus shift in the waist location is negligible here). After damage is initiated, damage grows

upstream as energy is absorbed from the incoming pulse. After propagating upstream approximately one Rayleigh range the irradiance is insufficient to sustain the plasma, and the damage growth ceases.

3. Focal size effect.

It is sometimes claimed that the damage irradiance (or fluence) depends on the size of the focal waist, with larger waists requiring lower irradiance. We measured damage threshold irradiances at waists of 7.5, 8.1, 12.7 and 17 μm , without correction for self focusing, these thresholds decreased as the focal waist increased. However, after taking into account the effect of self focusing, the damage thresholds for the 7.5, 8.1 and 12.7 μm waists were equal within our measurement uncertainty, the laser powers of these cases fall below the SBS threshold. The threshold for 17 μm waist lies above the SBS threshold, this damage threshold is slightly higher than those of the 7.5, 8.1 and 12.7 μm waists but we do not consider it reliable because of the presence of SBS.

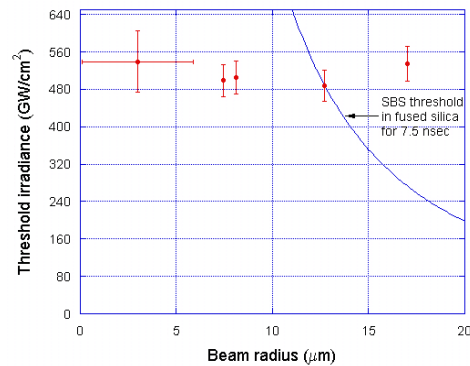

Figure 12: Damage threshold irradiance at different beam radii.

The data point lying in the upper left in figure 12 was measured using a curved mirror to retroreflect the laser beam back into the sample. This creates a standing wave with nodes and anti-nodes in the focal zone. The damage threshold energy was slightly less than one third of that without the retroreflector. The indicated error bars for this datum point are large because the alignment of retroreflected beam was imperfect. However, based on all of our data we conclude that there is no significant focal size effect for damage threshold irradiance.

4. Surface damage.

The measurements described above were all bulk damage. We also measured surface damage thresholds for various samples of D1 fused silica. We used only samples polished by an all-alumina process at Alpine Research Optics. We do not report on cerium oxide polished samples because they have a lower surface damage threshold, probably associated with residual cerium oxide incorporated into the sample surfaces. For the surface damage measurements we first located the focal waist exactly at the input face of the sample by maximizing the surface third harmonic. We measured a single shot surface damage threshold by setting the pulse energy about 30% above the bulk damage threshold to ensure optical breakdown on every shot. The single shot damage threshold

was deduced from the laser irradiance at which transmission terminated. This single-shot threshold was statistical with an 18% standard deviation. However, the highest damage threshold was nearly the same as the bulk damage threshold and we believe it represents the intrinsic surface damage threshold. The large statistical spread might be due to contaminants and defects on the sample's surface. To test this hypothesis we conditioned the sample surface by focusing on a single spot and gradually increasing the pulse energy from 5% of the bulk damage threshold until breakdown occurs. The surface damage threshold measured this way was also statistical with an 11% standard deviation, and the highest damage threshold was again nearly equal to the bulk threshold.

5. Influence of Yb³⁺ doping on the damage threshold in fused silica.

We also measured the damage threshold of 1% Yb³⁺ doped fiber preforms provided by Liekki. The low optical quality of the preform cores distorted the focus inside the sample so we measured the surface damage threshold. The measuring method was the same as outlined in the previous section. The highest surface damage threshold of the preforms equal to that of pure fused silica within 2%. This is a preliminary result; we plan further study of the damage threshold of Yb³⁺-doped fused silica.

6. Electron avalanche model.

An important question is whether an electron avalanche model can account for the damage in silica. The simplest electron avalanche rate model is described by the electron density rate equation [5]

$$\frac{dn}{dt} = \beta I^8(t) + \alpha n I(t) - n/\tau \quad (8)$$

where n is the electron density, β is the 8-photon absorption cross section, because it takes 8 photons at 1064 nm to excite an electron across the band gap of fused silica, α is the avalanche coefficient, and τ is the free electron lifetime due to electron-hole recombination. Because the electron lifetime in fused silica is only 150 fs [6], optical breakdown is nearly instantaneous on the time scale of our 7.5 ns pulses. The electron avalanche model matches our optical breakdown thresholds provided $\alpha\tau = 2 \times 10^{-4} \mu\text{m}^2/\text{W}$.

IV. Conclusions.

We report that the bulk damage threshold irradiance in fused silica is $5.0 \times 10^{11} \pm 7\%$ Watts/cm² for linearly or circularly polarized light, for a pulse duration of 7.5 ns, and a focal waist of 7.45 μm . The surface damage threshold is nearly the same as the bulk damage threshold if the sample's surface is properly prepared, and the surface damage threshold irradiance in 1% Yb³⁺ doped fiber preform was equal to that of pure fused silica.

The stimulated Brillouin threshold power in fused silica was 851.0 ± 2.9 kW for linearly or circularly polarized light for our pulse duration of 7.5 ns.

All of the reported damage threshold irradiances have been corrected for self focusing. Our measurements show that damage by ns pulses occurs at a precise threshold irradiance, not a threshold fluence. The damage threshold irradiance was slightly

increased above the SBS threshold, but there was no evident focal size effect on the damage threshold irradiance. Optical breakdown occurs on a time scale of 30 ps or less.

References

1. M. Soileau and M. Bass, IEEE J. Quan. Elec., **QE-16**, NO. 8, 814 (1980).
2. L. Gallais, J. Natoli, C. Amra, Optics Express, **10**, 1465 (2002).
3. N. Bloembergen, IEEE J. Quan. Elec., **QE-10**, NO 3, 375 (1974).
4. T. Tsang, Phys. Rev. A, **52**, 4116 (1995).
5. M. Lenzner, J. Kruger, S. Sartania, Z. Cheng, Ch. Spielmann, G. Mourou, W. Kautek, and F. Krausz, Phys. Rev. Lett., **80**, 4076 (1998).
6. P. Audebert et al., Phys. Rev. Lett. **73**, 1990 (1994).

Acknowledgement:

Supported by Laboratory Directed Research and Development, Sandia National Laboratories, U.S. Department of Energy, under contract DE-AC04-94AL85000.